



XTZ 99.26 Walnut
XTZ 99.26 Black Matt
XTZ 99.26 White

High-End Monitor speaker

User manual

© 2009 XTZ AB , www.xtz.se

Table of contents

	Page:
Contents	3
About XTZ	3
Technical presentation	4
Preparations	5
Practice of sound / Installation and placement tips	6
Mounting /Area of usage	8
Sound adjustment	9
Technical specifications	10
Service & Support	11

Contents

Contents

Congratulations to your purchase of the XTZ 99.26!

When combined with surround audio/video electronics, you will experience motion picture sound or music records played deeply and naturally. Now when you watch your favourite movie or listen to your reference music CDs, you will hear and feel the sound surrounding you in the same way as originally intended by the mastering engineers.



Read the manual before using the product and use all possibilities carefully.

About XTZ

Philosophy

Our reference and starting point is to reproduce a natural sound, taking into account that acoustics always is a matter of taste.

XTZ Goal

Our main goal is to provide the best value for money.

Our concept:

- Cut down the numbers of middlemen
- Put more money into product quality and less on advertising.
- Cost effective large volume manufacturing
- Provide perfect technical compromises

Contact

Website: www.xtz.se
E-mail: info@xtz.se

Technical presentation

Cabinet design

The box design with a narrow baffle and curved side is not only an esthetical neat shape, but also provides some advantages in terms of acoustics, since non parallel walls suppress internal resonances of the cabinet.

The cabinet is made from sturdy MDF board, which offers good sonic qualities.

The cabinet is further strengthened with bars, which in total ensures a very stable construction.

Tweeter driver

We have selected a ribbon tweeter which provides superior transient response and a very flat frequency response. The ribbon cone is super light and only 18 microns thick. It is a sandwich construction made from rosin-aluminium-rosin that has been hardened at 320 degrees Celsius.

The magnet system is a 2 row high-efficient neodymium magnets in a moulded chassis of ceramic carbon steel.

Fishbone shaped contactors in aluminium, results in a low connection resistance and good heat distribution.

The driver has high power durability and handles frequencies up to 40000 Hz which makes it DVD-Audio and SACD-ready.

Woofers/midrange driver

After evaluating a large number of drivers from different manufacturers we selected one from Seas, a company that has a solid reputation in the area of high quality speaker drivers. You find Seas drivers in many well-known High End speakers.

For woofer/midrange we decided on a 6,5" magnesium driver from the Seas Excel series that have extreme performance. We claim that finding a better 6,5" driver on the market is a very difficult task.

The surface treated magnesium cone is extremely light but still extremely stiff and effectively reduces resonances.

The rubber surrounding makes sure that no edge resonances are present.

The moulded metal basket is a "high flow" type that is acoustically transparent with high precision as the basket is shaped exactly due to the moulding process. This makes sure that the basket is very stable and efficiently reduces resonances. The basket is absolutely non-magnetic, which contributes to a higher efficiency of the driver.

A strong magnet combined with the light cone ensures a high efficiency and a good transient response.

Heavy copper rings mounted above and below the T-shaped pole piece reduce non linear- and modulation-distortion and increases the overload margin.

The copper plating of the top and bottom plates along with a solid copper phase plug improves the heat conduction and thus contributes to the high power durability.

Gold plated terminals reduce contact resistance and serves as anti-corrosion.
Large windows in the basket both above and below the spider reduces sound reflection, air flow noise and cavity resonances.

Crossover / Binding post

We have selected a -12 dB crossover that has a fast transient response and a minimum of phase shifting.

The connectors are gold plated bi-wiring types so you can connect to the amplifier with double cables (bi-wiring), or connect to two amplifiers (bi-amping) for further improvement of the sound. The following connecting methods are available:

1. Upper terminal + lower terminal (loops present)

Default setting, the loudspeaker is fed with the entire frequency range.

Without the loop between upper and lower terminal:

2. Upper terminal. The signal is only fed to the tweeter.

3. Lower terminal. Now the signal is fed to the woofer only.

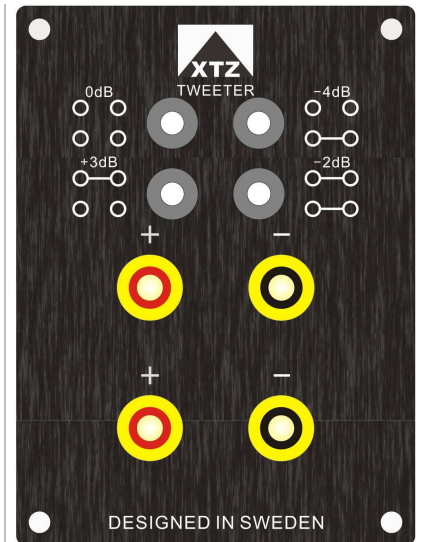

Preparations

Unpacking

Carefully unpack the speaker, and pay attention so you don't break anything. If possible, save the box for future transportations. If there should be damage to the loudspeaker, please contact your retailer.

Accessories

Bass reflex plug

User manual

Rubber feet

Loops for level adjustment

Practice of sound / Installation and placement tips

	<p>This chapter contains common information on loudspeaker placement and installation.</p> <p>These are general rules, so there are exceptions.</p>	
In which room do you achieve the best sound?	<p>No matter how good the equipment is, in the wrong listening environment it will inevitably sound bad. There are some basic rules concerning a proper loudspeaker installation:</p>	
Reflections	<p>Carpets, curtains and soft furniture absorb mid range and high frequency sound, and this is preferable. Big empty areas, on the contrary, produce hard reflections that may lead to a blurry dialogue. Apart from colouring the sound, the perspective of the sound will deteriorate. Reflections in the room can roughly be compared to the reflections that cause ghost pictures on a TV screen.</p>	
Amplification of bass frequencies	<p>A loudspeaker that is placed near a wall, ceiling or floor will amplify lower frequencies in a sometimes not desirable way (since it may lead to an indistinct sound reproduction). This amplification becomes even more obvious if the loudspeaker is placed near a corner. Thus, for a sound as clear as possible, the loudspeaker should be placed at least 30 cm (about 12 inch) away from the wall.</p> <p>Some constructions are made to be placed close to a wall.</p>	
Furniture	<p>Be aware that furniture may vibrate and cause noise at high levels.</p>	
Room dimension	<p>Quadratic rooms or rooms where the length is near twice as long as the width should be avoided, since they may create unwanted resonance.</p>	
Placement of the subwoofer	<p>The placement of the subwoofer in the room dramatically affects the overall frequency response and sound level of the system. At low frequencies the effect of the room is strong. Even a slight change in the subwoofer's location can make a significant difference in the frequency balance. Patience and experimentation is needed to find the optimal placement. The placement affects the phase difference between the main loudspeakers and the subwoofer.</p> <p>One basic rule is to place the subwoofer together with or near the front system (especially important if the front loudspeaker also covers bass frequencies) as this will minimize the risk of phase errors in the room.</p>	

Cables

Try to keep cables as short as possible. Due to its electrical features, a long conductor will have a bigger influence on the sound than a short one. It may also work as an antenna and receive various signals that may become a constant noise in an active subwoofer for example.

Make sure that all connections are clean and not oxidized. All connections should be mechanically stable, both power, signal and loudspeaker cables. Signal cables should be separated from other cables.

Front speakers

To get the best result the front speakers should be placed symmetrically in front of the listener. The distance between the front speakers should be around 80% of the distance to the listener. In other words, the recommended angle between the front speakers should be 45° .

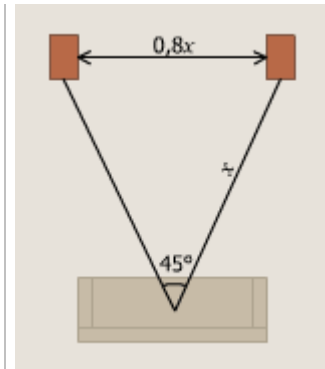
**Why use two subwoofers?**

There are benefits having two subwoofers instead of one.

The maximum sound pressure level will be higher.

Less dips and standing waves in the room and a better frequency response in the room (and in sweet spot).

The power needed will be less to reach the same SPL as with one subwoofer.

Finally

Please remember that good sound is a matter of taste, so you have to experiment to obtain your favourite one.

We wish you best of luck!

Mounting and Connecting tips

Mounting alternatives

Normally the XTZ 99.26 is placed standing by a wall. The wall behind and besides the loudspeaker have influence both on the bass level and the bass characteristics, so please be patient and try different distances to the rear and side walls.

Connect using the correct phase

Always connect using the correct phase, from the +-pole on the amplifier to the +-pole on the loudspeaker and corresponding for minus (-).

If you by accident connect the other way, there is no risk of damage. However, the sound will not be correct, especially in the lower frequencies.

Overload

At high load during extensive time periods, there is always the risk of overloading the driver and amplifier.

All loudspeakers have a limited power capacity, so be careful not to play extremely loud and not to increase treble or bass settings to much.

The initial playing time

It takes about 50 to 100 hour of initial playing time for the driver to sound optimal. During this time, the speaker may be used normally.

Sound settings

Room Tuning - Mechanical adjustment of the boundary frequency



By using the supplied bass plugs in the bass reflex gates, you can alter the lower boundary frequency on the XTZ 99.26.

Also the treble level may be adjusted, which allows you to perfectly adjust the parameters to fit the room, equipment and your own taste.

Closed port

With the bass plug mounted in the bass reflex port, the cabinet is closed and the loudspeaker operates as a closed construction which produces a more "tight" bass reproduction.

Bass reflex

With no plug present in the port you get a higher bass level and the loudspeaker is capable of handling lower frequencies.

This setting also depends on the size and shape of the room, and also on your own taste, so please has patience when trying out your preferred setting.

Level adjustment in the treble range

In the treble range the level is adjustable in four different steps using the supplied loop connectors.

Level adjustment in the treble range:

Mode 1/ 0dB

In this mode the sound is neutral with a flat frequency response.

Mode 2/ +3dB

In this mode the treble level is increased by 3dB.

Mode 3/ -2dB

In this mode the treble level is decreased by 2dB.

Mode 4/ -4dB

In this mode the treble level is decreased by 4dB.

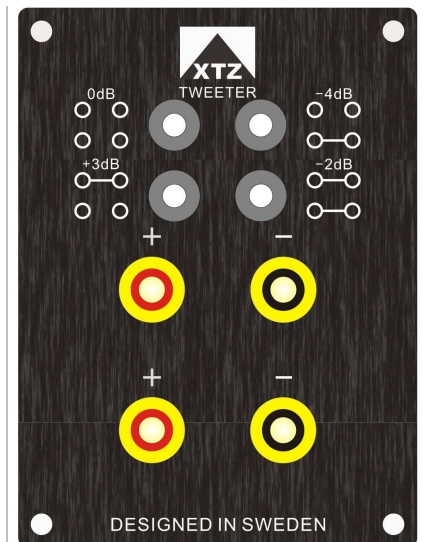

Terminal /Biwiring

We have selected a -12 dB crossover that has a fast transient response and a minimum of phase shiftings.

The connectors are gold plated bi-wiring types so you can connect to the amplifier with double cables (bi-wiring), or connect to two amplifiers (bi-amping) for further improvement of the sound. The following connecting modes are available:

1. Upper terminal + lower terminal (loops present)

Default setting, the loudspeaker is fed with the entire frequency range.

Without the loop between upper and lower terminal:

2. Upper terminal. The signal is only fed to the tweeter.

3. Lower terminal. Now the signal is fed to the woofer only.

Technical specifications

Construction type	2-way, Bass reflex cabinet that may be set as a closed box. The treble level is adjustable in four different levels.	
Dimensions	244 x 379 x 352 mm (W x H x D)	(with front cover)
Weight	9 kg/pc	
Magnetically shielded	No	
Impedance	4-8 ohm	
Binding post	Gold plated bi-wiring / Banana plug / Pole screw	
Efficiency	88dB	
Power	300 W Short term IEC 268-5 100 W Long term IEC 268-5	
Tweeter driver	Ribbon tweeter, SACD/DVD-Audio-ready, Sandwich ribbon cone in aluminium, neodymium magnets, chassis made in ceramic carbon steel.	
Woofers/midrange driver	6,5" SEAS Excel, Magnesium driver, moulded "high flow" driver basket, powerful magnet. 1900 gram.	
Connections and settings	<ul style="list-style-type: none"> • Gold plated biwiring. • Bass reflex settable to closed box. • The treble level is adjustable in 4 different modes. 	

Service & support

"Do-It-Yourself"-service

We apply "do-it-yourself" service on all XTZ products.

If you by yourself are able to find out what part of the loudspeaker is defective, you are fully allowed to dismount that part (which would normally be a driver, a filter or the amplifier) and send it back to us for replacement.

However, if you are not certain about how to do it, please contact us before taking the loudspeaker apart. We can also help you find the fault.

You can of course always choose to return the loudspeaker; therefore you should save the original package.

To aid service, XTZ products are constructed and produced using common technology, so that most people are able to "unscrew" the loudspeaker using common tools.

If something is broken

If you cause additional damage by yourself when dismounting the defective part, the warranty still applies if it is obvious that the part had a manufacturing defect. In other cases however, the warranty does not apply if you cause other damages to the loudspeaker.

Where to send the product for a warranty repair

For service we refer to our retailers.

For questions regarding service, please contact us by email support@xtz.se

Web page: www.xtz.se

ALWAYS pack the product / part very carefully.

Unfortunately damages during transportation are very common. If the package is insufficient, the transporting company does not compensate damages.

Always enclose a copy of the receipt and a description of the defect.

Support

Please contact our free of charge support if you need installation advice, or if any problem occurs during the installation.

Contact us by e-mail support@xtz.se and include your phone number if you wish verbal help, and we will call you back.